

Electric Actuator NA Series



Performance

Type	Max Output Torque		Operating Time (90/sec)		Rated Current (A)						Motor		Duty Cycle	Max Stem Dia	Handle Turns	Weight
	Kg.m	N.m	50Hz	60Hz	DC24V	AC110V	AC220V	AC230V	AC380V	AC440V	W	Class	S4 (%)	mm		kg
NA006	6	60	17	14	2.5	0.7	0.38	0.38	0.15	0.15	15	F	50	22	8.5	9
NA009	9	90	17	14	3.5	1.1	0.51	0.56	0.18	0.18	25	F	50	22	8.5	9
NA015	15	150	20	17	5.0	1.6	0.75	0.75	0.3	0.3	40	F	50	22	10	11.5
NA019	19	190	20	17	5.0	1.6	0.75	0.75	0.3	0.3	40	F	50	22	10	11.5
NA028	28	280	24	20	6.5	1.6	0.75	0.75	0.32	0.32	40	F	50	32	12.5	14
NA038	38	380	24	20	-	2.3	1.1	1.06	0.34	0.32	60	F	30	32	12.5	14
NA050	50	500	24	20	-	3.5	1.2	1.2	0.47	0.47	90	F	25	32	12.5	14
NA060	60	600	29	24	-	3.5	1.2	1.2	0.47	0.47	90	F	25	42	14.5	24
NA080	80	800	29	24	-	3.8	1.8	1.8	0.75	0.75	180	F	25	42	14.5	24
NA100	100	1000	29	24	-	4.0	2.0	2.0	0.85	0.85	180	F	25	42	14.5	24
NA150	150	1500	87	72	-	3.5	1.2	1.2	0.47	0.47	90	F	25	75	43.5	60
NA200	200	2000	87	72	-	3.8	1.8	1.8	0.75	0.75	180	F	25	75	43.5	60
NA250	250	2500	87	72	-	4.0	2.0	2.0	0.85	0.85	180	F	25	75	43.5	60
NA300	300	3000	116	96	-	4.0	2.0	2.0	0.85	0.85	180	F	25	75	58	60

Standard Specification

Enclosure	Watertight Ingress Protection 67 Nema 4 and 6
Ambient Temperature	-20°C to +70°C , 150°C / 1hr (Option: -60°C, 400°C / 1hr)
Power Supply	110 / 220 VAC 50/60Hz , 380 / 440 VAC 50/60Hz Option : AC 24V , DC 24V
Torque Switches	2 Open / Close (Except NA006, NA009)
Limit Switches	2 Open / Close, 250VAC 15A Rating
Stall Protection	Built - in Thermal Protection (Open 150°C ± 5°C / Close 97°C ± 15°C)
Travel Angle	90±5°
Indicator	Continuous Position Indicator
Manual Override	Hand / Auto Decoupling Mechanism
Self Locking	Provided by means of Worm Gearing
Mechanical Stops	External Adjustable Screws
Space Heater	20W
Cable Entries	2-PF 3/4", 2-NPT 3/4", 2-M20 x 1.5 (Pitch)
Lubrication	Shell Gadus S2 V220 2
Material	Aluminium
Surface Treatment	Anodizing
External Coating	Polyester(TGIC-Free)

Optional Specification

E X P	Explosion Proof / Ex d IIB T4
IP68	Watertight Enclosure IP68 / 1bar 72h (KTL)
A L S	Auxiliary Open, Close Limit Switches
A T S	Auxiliary Open, Close Torque Switches
P I U	Potentiometer 1K Ohm
P C U	Proportional Control Unit / Input : DC 4-20mA, DC 0-10V / Output: DC 4-20mA
C P T	Current Position Transmitter
L C U	Local Control Unit
I M S	Integral Motor Starter (On-Off Action)
E X T	Travel Angle (120°, 135°, 180°, 270°, 300°)
D C M	Power Supply DC 24V (NA006-NA028)
Field-Bus	Profi-Bus, Mod-Bus, Can-Bus

Configuration

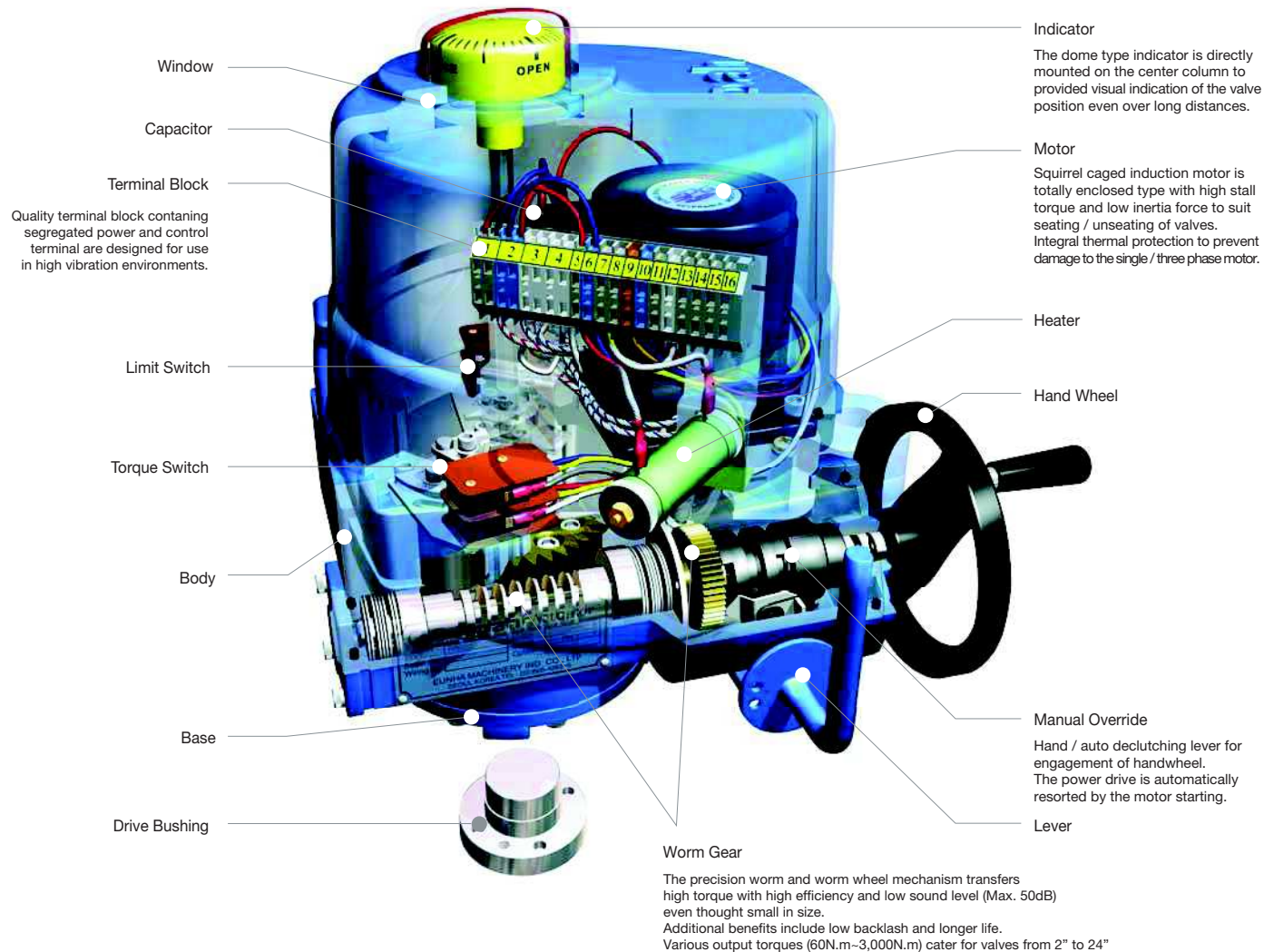

FEATURES

- **SEALING**

Standard enclosure with o-ring sealing is watertight to IEC IP67, NEMA 4 and 6. The actuator is available with optional explosion proof enclosure.

- **WIRING**

Electric wiring of control circuit is standardized for single and three phase power supply in a single module. Multiple terminal contacts sufficiently cover additional requirements such as auxiliary contacts for interlocking and other options.

- **COMPONENT ARRANGEMENT**

Mechanical and electrical module can be separated easily to improve assembling, maintenance and alteration of electrical requirements. Actuator has enough internal space for optional accessories.

- **HAND WHEEL**

Size of hand wheel is designed for safe and efficient emergency manual operation.

- **MANUAL OVERRIDE**

Hand / auto declutching lever for hand wheel engagement. The power drive is automatically restored by motor start.

- **ADAPTION**

Base mounting is standard to ISO5211. Drive bushing is removable for matching to valve stem requirement. The actuator position on the valve can be selected for 4 positions by means of 4 bolt holes in the drive bushing.

- **HEATER**

A space heater inside the actuator prevents condensation due to temperature and weather changes. Standard 20W heater keeps all electrical components in the actuator clean and dry.

- **LIMIT SWITCHES**

The limit switch is activated by means of a simple and yet reliable cam mechanism mounted and driven by the center column. The valve position can be accurately and easily set with the simple adjustable switch mechanism. The set position is permanent and is not affected by over-torque resulting from manual operation.

- **TORQUE SWITCHES**

Cam activated torque switches are easily adjustable to provide over-load protection.

- **SELF LOCKING**

Rolled steel wormgear on aluminium bronze wormwheel self locking to prevent valve back drive on control signal or power failure.

Optional

ALS (Auxiliary Limit Switches)

Providing the dry contact signal to check valve's positions (cam switches structure).

ATS (Auxiliary Torque Switches)

Providing the dry contact signal send to customer's panel as fault signal (cam switches structure).

CPT (Current Position Transmitter)

Combined with P.I.U and transfer output signal (DC 4-20mA) from P.I.U's value of resistance.

- Output Signal : DC 4-20mA

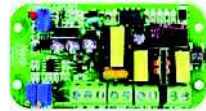

PCU (Proportional Control Unit)

Combined with P.I.U and control the valve's position proportionally by input signal and provide valve's position as their output signal.

- Input signal : DC 4-20mA / DC 1-5V / DC 2-10V
- Output signal : DC 4-20mA



PIU (Position Indication Unit)

Providing resistance value (0~1KΩ) according to valve's position.



LCU (Local Control Unit)

LCU can be installed either on the actuator or distantly by cable. It can be controlled conveniently as it consists of Local / Remote Switch, Open / Stop / Close Switch and LED Lamp



Field-Bus

Field-Bus can control 126pcs of electric actuators at the same time using communication hardware system based on PC.

(Profi-Bus, Mod-Bus, Can-Bus) For more information please contact EMICO.



NA Integral Standard Specification

Main Power	110/220 VAC 50/60Hz , 380/440 VAC 50/60Hz
Internal Control Power	24 VDC
External Control Power	110 VAC, 24 VDC
Torque Switches	2 Open / Close (Except NA006, NA009)
Limit Switches	2 Open / Close, 250VAC 15A Rating
Control Unit	1. Non Intrusive Push Buttons [Open/ Stop/ Close] 2. Non Intrusive Selector Switch [Remote / Off / Local] 3. Reversing Contactor 4. Phase Discriminator
Position Indicator	Digital Display (0~100%)
Remote Dry Contact (Max 250VAC 5A)	1. Full Open / Close 2. Opening / Closing 3. Open / Close Over Torque 4. Monitor (Remote / Local)
Cable Entries	Standard 1-PF 1", 2-PF 3/4"
	Option 1-NPT 1", 2-NPT 3/4" 1-M25 Pitch 1.5 , 2-M20 Pitch 1.5
Potentiometer	0 ~ 1 KΩ
Lubrication	Shell Gadus S2 V220 2
Consist of Materials	Aluminium
Surface Treatment	Anodizing
External Coating	Polyester(TGIC-Free)

NA Integral Optional Specification

P C U	PCU enables the actuator to be controlled form a distance. Input: DC 4-20mA, DC 1-5V, DC 2-10V / Output: DC 4-20mA
C P T	CPT outputs by converting the actuator's place value to ampere. Output Signal: DC 4-20mA
F D B	FDB is used when controlling actuators using communication hardware system based on PC. (Profi-Bus, Mod-Bus, Can-Bus) For more information please contact EMICO.

Dimension

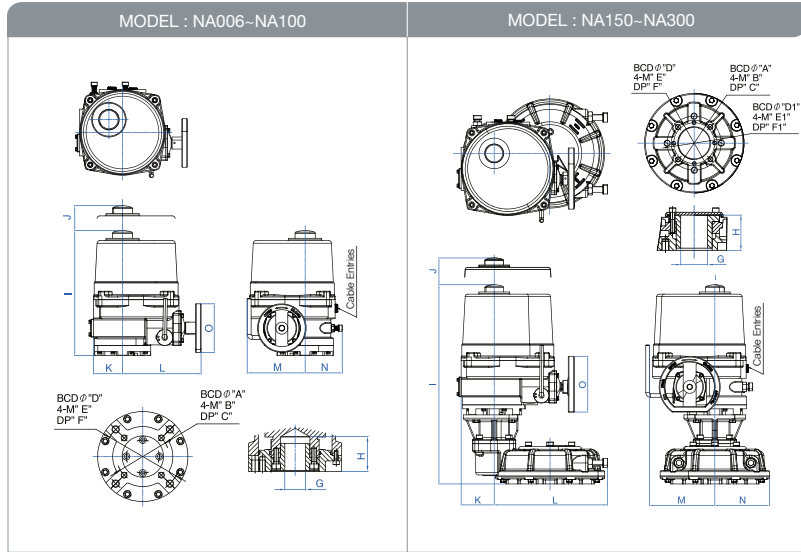

Type	NA006 NA009	NA015 NA019	NA028 NA038 NA050	NA060 NA080 NA100	NA150, NA200, NA250, NA300	
A	BCD70	BCD70	BCD102	BCD125	BCD125	
B	4-M8	4-M8	4-M10	4-M12	4-M12	
C	12	12	18	22	22	
Flange ISO5211	F07	F07	F10	F12	F12	
D	D1	-	BCD102	BCD125	BCD140	BCD165
E	E1	-	4-M10	4-M12	4-M16	4-M20
F	F1	-	15	18	22	25
Flange ISO5211	-	F10	F12	F14	F14	F16
Option	BCD82	BCD82	-	BCD102(F10)	-	
G(MAX)	Key	22	22	32	42	75
	Square	20	20	26	34	65
H	46	46	55	62	100	
I	270	274	321	362	554	
J	108	108	130	178	178	
K	55	70	75	92	92	
L	174	184	202	223	315	
M	120	139	149	192	192	
N	68	85	95	105	152	
O	102	102	125	155	170	
Cable Entries	2-PF3/4"	2-PF3/4"	2-PF3/4"	2-PF3/4"	2-PF3/4"	
	2-M20x1.5	2-M20x1.5	2-M20x1.5	2-M20x1.5	2-M20x1.5	
	2-NPT3/4"	2-NPT3/4"	2-NPT3/4"	2-NPT3/4"	2-NPT3/4"	

NA On-Off Type + Butterfly Valve

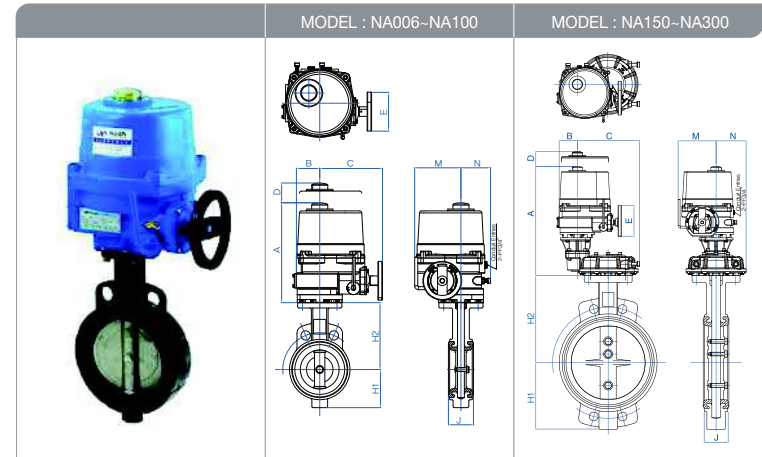

Dimension(mm)											
Size	Model	A	B	C	D	E	M	N	H1	H2	J
80A	NA006	270	55	174	108	102	120	68	78	136	46
100A	NA009	270	55	174	108	102	120	68	89	157	46
125A	NA015	274	70	184	108	102	139	85	109	175	52
150A	NA019	274	70	184	108	102	139	85	124	195	56
200A	NA028	321	75	202	130	125	149	95	174	226	60
250A	NA038	321	75	202	130	125	149	95	205	268	68
300A	NA060	362	92	223	178	155	192	105	228	301	78
350A	NA080	362	92	223	178	155	192	105	254	327	78

Gear Box Type											
Size	Model	A	B	C	D	E	M	N	H1	H2	J
400/450A	NA150	554	92	315	178	170	192	152	290/318	348/400	102/108
500A	NA200	554	92	315	178	170	192	152	348	435	125
600A	NA250	554	92	315	178	170	192	152	461	508	150
600/650A	NA300	554	92	315	178	170	192	152	461/487	508/542	150/160

* Note : Makers standard 220V. Other AC110V, 380V, 440V, OPTION DC 24V contact with the manufacture.
* Rating : JIS 10K Wafer Type

NA On-Off Type + Ball Valve

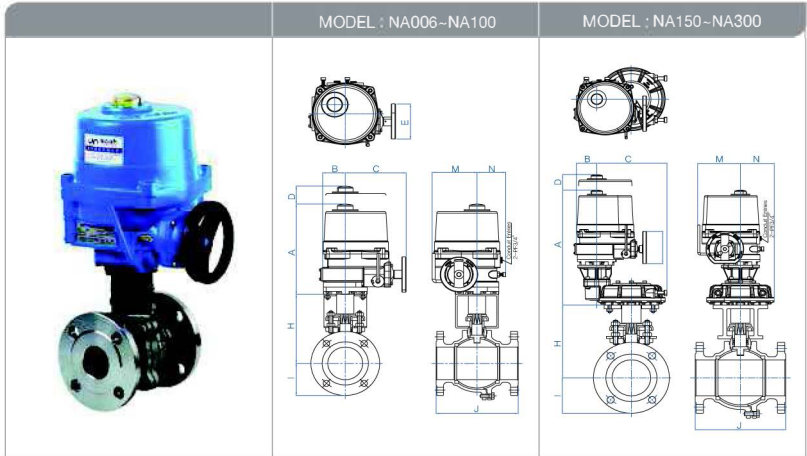

Dimension(mm)											
Size	Model	A	B	C	D	E	M	N	H	I	J
40A	NA006	270	55	174	108	102	120	68	196	70	165
50A	NA009	270	55	174	108	102	120	68	204	72.5	178
65A	NA015	274	70	184	108	102	139	85	216	87.5	190
80A	NA019	274	70	184	108	102	139	85	236	92.5	203
100A	NA028	321	75	202	130	125	149	95	254	105	229
125A	NA050	321	75	202	130	125	149	95	310	125	356
150A	NA060	362	92	223	178	155	192	105	335	140	394
200A	NA100	362	92	223	178	155	192	105	406	165	457

Gear Box Type											
Size	Model	A	B	C	D	E	M	N	H	I	J
250A	NA200	554	92	315	178	170	192	152	442	200	533
300A	NA250	554	92	315	178	170	192	152	506	222.5	610
300A(350A)	NA300	554	92	315	178	170	192	152	506	222.5	610

※ Note : Makers standard 220V. Other AC110V, 380V, 440V, OPTION DC 24V contact with the manufacture.
 ※ Rating : JIS 10K RF