

ELECTRIC ACTUATOR SR SERIES 03

<http://www.actuator-solutions.com>



Performance

Type	Max Output Torque		Spring Return Time(90°) sec	Operating Time (90°) (Open/Close) sec	Motor		Duty Cycle S2 (min)	Mounting Base ISO5211	Handle Turns	Weight kg
	Kg.m	N.m			W	Class				
SR03	3	30	4, 7, 10 Selection	10 ~ 35, Speed Control	40	E	15	F03/F04/F05	8.5	9.2

Standard Specification

Enclosure	Watertight Ingress Protection 67 Nema 4 and 6, Flameproof Enclosure Ex d IIB T4
Ambient Temperature	-20°C ~ 55°C
Power Supply	1Ph AC110~230V Free Voltage 50/60Hz, DC24V
Limit Switch	Open/Close Limit Switch (250VAC 15A)
A.L.S	Auxiliary Open, Close Limit Switches
Fail Action Speed Control	4, 7, 10 sec
P,I,U	Potentiometer 1 K Ohm
Travel Angle	90° ± 5°
Indicator	Continuous Position Indicator
Self Locking	BLDC Board Control
Manual override	External Adjustable Screws
Mechanical Stops	Hand / Auto Clutching Mechanism
Space Heater	20W
Cable Entries	2-PF 3/4"
	Option : 2-M20x1.5, 2-NPT 3/4" (* It identically applies to EXP Type)
Lubrication	Shell Gadus S2 V220 2
Consist of Materials	Aluminium Alloy
Surface Treatment	Anodizing
Coating	Polyester (TGIC - Free)

Optional Specification

BLDC PCU	Proportional Contact Unit (Modulation) Input : 4-20mA DC 1~5VDC, 2~10VDC, 0~5VDC, 0~10VDC Output : 4-20mA DC
FieldBus	ProfiBus, Mod-Bus, Can-Bus

Configuration

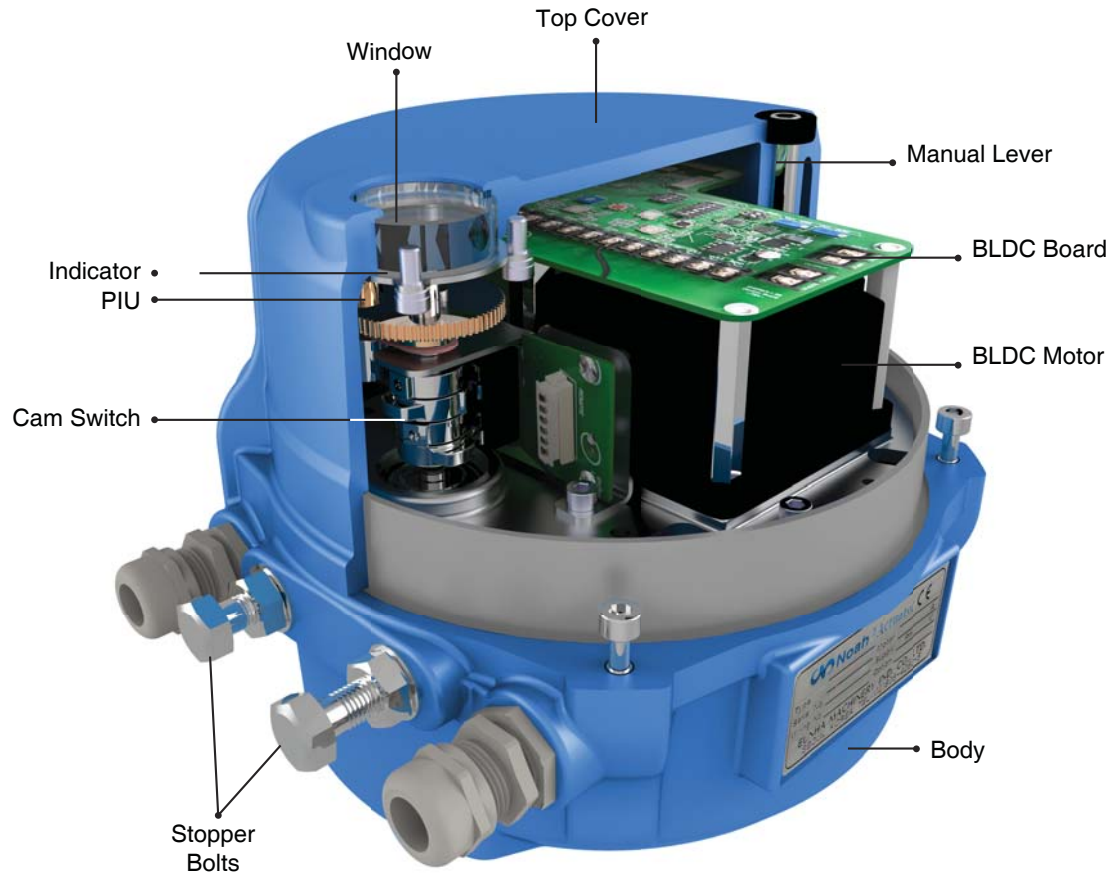

Features

Sealing

Standard enclosure with o-ring sealing is watertight to IP67, NEMA 4 and 6. The actuator is available with optional explosion-proof enclosure.

Motor

Squirrel caged induction motor is totally enclosed type with high stall torque and low inertia force to suit seating/unseating of valves. Integral thermal protection to prevent damage to the single phase motor.

Adaption

3 ISO mounting pads are provided for greater flexibility. (F03, F04, F05)

Wiring

Electric wiring of control circuit is standard size for single and three phase power supply in a signal module. Multiple terminal contacts sufficiently cover additional requirements such as auxiliary contacts for DCS, interlocking and other options.

Heater

A space heater inside the actuator prevents condensation due to temperature and weather changes. Standard 20W heater keeps all electrical components in the actuator lean and dry.

How to operate SR03

- Open/Close operation by motors
- In case of power failure, actuators can be operated to Full Open or Full Close position by the power of the spring.
- Operation to open position using the lever.

Dimension

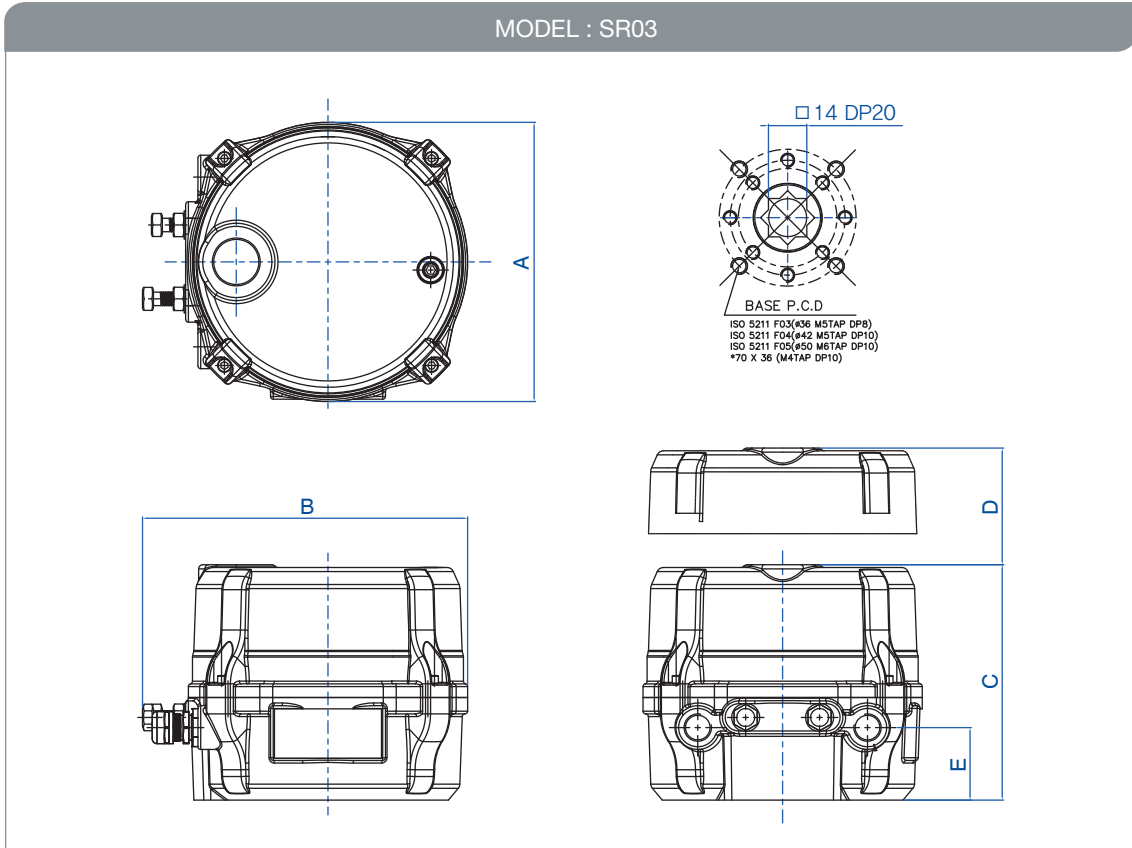

Model	A	B	C	D	E	F	G	H
SR03	204	238	172	110	164	134	20	200